

PHYSICS

PART -A- PHYSICS

This question contains statement - 1 and Statement -2. Of the four chices given after the statements, choose the one that best describes the two statements.

01. **Statement 1 :** For a charged particle moving from point P to point Q, the net work done by an electrostatic field on the particle is independent of the path connecting point P to point Q.

Statement 2 : The net work done by a conservative force on an object moving along a closed loop is zero.

- 1) Statement - 1 is true, Statement - 2 is false
- 2) Statement - 1 is true, Statement - 2 is true ; Statement - 2 is the correct explanation of Statement - 1.
- 3) Statement - 1 is true, Statement - 2 is true ; Statement - 2 is not the correct explanation of Statement - 1
- 4) Statement - 1 is false, Statement - 2 is true.

Ans. 3

02.

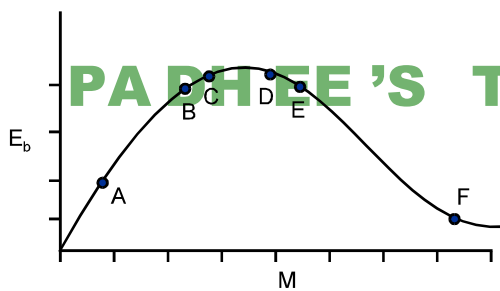

PADHEE'S TUTORIAL PVT. LTD.

The above is a plot of binding energy per. nucleon E_b , against the nuclear mass M ; A, B, C, D, E, F correspond to different nuclei. Consider four reactions :

- a) $A + B \rightarrow C + \epsilon$ ii) $C \rightarrow A + B + \epsilon$ iii) $D + E \rightarrow F + \epsilon$ and iv) $F \rightarrow D + E + \epsilon$

where ϵ is the energy released ? In which reactions is ϵ positive ?

- 1) (i) and (iv) 2) (i) and (iii) 3) (ii) and (iv) 4) (ii) and (iii)

Ans. 1

03. A p - n junction (D) shown in the figure can act as a rectifier. An alternating current source (V) is connected in the circuit.

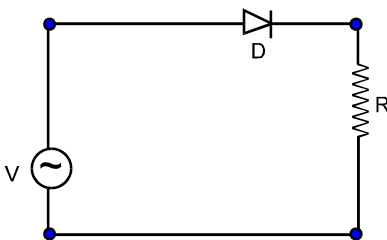

The current (I) in the resistor (R) can be shown by :

- 1)
- 2)
- 3)
- 4)

Ans. 3

04. The logic circuit shown below has the input waveforms 'A' and 'B' as shown. Pick out the correct output waveform.

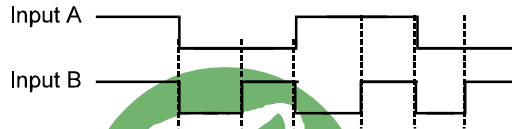
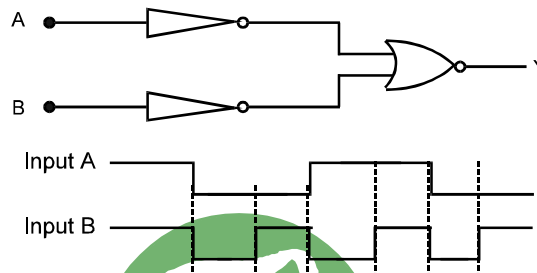

Output is

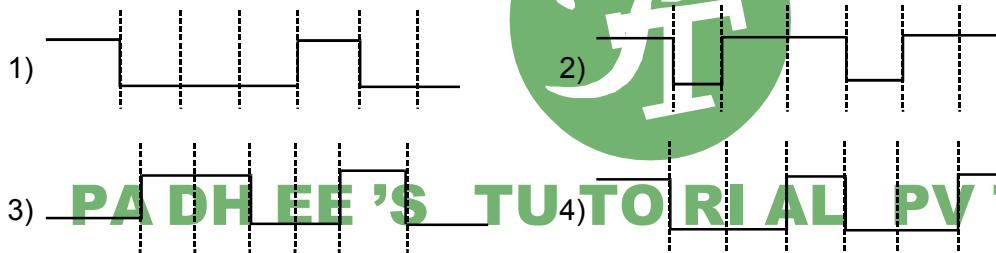

Ans. 1

A	B	Output
0	0	0
0	1	0
1	0	0
1	1	1

05. If x , v and a denote the displacement, the velocity and the acceleration of a particle executing simple harmonic motion of time period T , then, which of the following does not change with time ?

- 1) $a^2 T^2 + 4\pi^2 v^2$ 2) aT / x 3) $aT + 2\pi v$ 4) aT / v

Ans. 2

$$x = A \sin \omega t$$

$$v = A\omega \cos \omega t$$

$$a = -A\omega^2 \sin \omega t$$

$$\Rightarrow \frac{aT}{x} = \frac{4\pi^2}{T} = \text{constant}$$

06. In an optics experiment, with the position of the object fixed, student varies the position of a convex lens and for each position, the screen is adjusted to get a clear image of the object. A graph between the object distance u and the image distance v , from the lens, is plotted using the same scale for the two axes. A straight line passing through the origin and making an angle of 45° with the x -axis meets the experimental curve at P. The coordinates of P will be :

- 1) $(2f, 2f)$ 2) $\left(\frac{f}{2}, \frac{f}{2}\right)$ 3) (f, f) 4) $(4f, 4f)$

Ans. 1

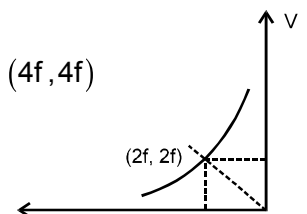

07. A thin uniform rod of length l and mass m is swinging freely about a horizontal axis passing through its end. Its maximum angular speed is ω . Its centre of mass rises to a maximum height of :

- 1) $\frac{1}{3} \frac{l^2 \omega^2}{g}$ 2) $\frac{1}{6} \frac{l \omega}{g}$ 3) $\frac{1}{2} \frac{l^2 \omega^2}{g}$ 4) $\frac{1}{6} \frac{l^2 \omega^2}{g}$

Ans. 4

$$\frac{mgl}{2} + \frac{1}{2} l\omega^2 = mgd$$

$$\Rightarrow \frac{mgl}{2} + \frac{1}{2} \frac{ml^2 3}{\omega^2 = mgd} \Rightarrow \frac{gl}{2} + \frac{\omega^2 l^2}{6} = gd$$

$$d = \frac{l}{2} + \frac{\omega^2 l^2}{6g} \quad \therefore \text{height rised} = \frac{\omega^2 l^2}{6g}$$

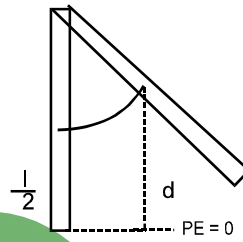

08. Let $P(r) = \frac{Q}{\pi R^4} r$ be the charge density distribution for a solid sphere of radius R and total charge Q . For a point 'P' inside the sphere at distance r_1 from the centre of the sphere, the magnitude of electric field is :

- 1) 0 b) $\frac{Q}{4\pi\epsilon_0 r_1^2}$ 3) $\frac{Qr_1^2}{4\pi\epsilon_0 R^4}$ 4) $\frac{Qr_1^2}{3\pi\epsilon_0 R^4}$

Ans. 3 **PA DH EE 'S TU TO RI AL PV T. LT D.**

$$\rho = \frac{Qr}{\pi R^4}$$

$$dq = \rho dV = \rho \cdot 4\pi r^2 dr$$

$$= \frac{Qr}{\pi R^4} \cdot 4\pi r^2 dr = \frac{4Q}{R^4} \cdot r^3 dr$$

$$\rho = \frac{4Q}{R^4} \int_0^{r_1} r^3 dr = \frac{4Q}{R^4} = \frac{r_1^4}{4} = \frac{Q r_1^4}{R^4}$$

$$\text{By Gauss law } E4\pi r_1^2 = \frac{\rho}{\epsilon_0} = \frac{Qr_1^4}{R^4 \epsilon_0} \Rightarrow E = \frac{Qr_1^2}{4\pi\epsilon_0 R^4}$$

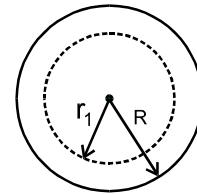

09. The transition from the state $n=4$ to $n=3$ in a hydrogen like atom results in ultraviolet radiation. Infrared radiation will be obtained in the transition from :

- 1) $2 \rightarrow 1$ 2) $3 \rightarrow 2$ 3) $4 \rightarrow 2$ 4) $5 \rightarrow 4$

Ans. 4

For infrared radiation, λ should be more. Hence ΔE should be less.

10. One kg of a diatomic gas is at a pressure of $8 \times 10^4 \text{ N/m}^2$. The density of the gas is 4 kg/m^3 . What is the energy of the gas due to its thermal motion ?

- 1) $3 \times 10^4 \text{ J}$ 2) $5 \times 10^4 \text{ J}$ 3) $6 \times 10^4 \text{ J}$ 4) $7 \times 10^4 \text{ J}$

Ans. 2

$$m = 1 \text{ kg}$$

$$\rho = 8 \times 10^4 \text{ N/m}^2$$

$$E = \frac{fnRT}{2} = \frac{fpv}{2} = \frac{5}{2} \times p \cdot \frac{m}{\rho} = \frac{5}{2} \times 8 \times 10^4 \times \frac{1}{4} = 5 \times 10^4 \text{ J}$$

This question contains Statement - 1 and Statement -2. Of the four choices given after the statements, choose the one that best describes the two statements.

11. **Statement : 1** : The temperature dependence of resistance is usually given as $R = R_0 (1 + \alpha \Delta t)$. The resistance of a wire changes from 100Ω to 150Ω when its temperature is increased from 27°C to 227°C . This implies that $\alpha = 2.5 \times 10^{-3} / ^\circ \text{C}$.

Statement 2 : $R = R_0 (1 + \alpha \Delta T)$ is valid only when the change in the temperature ΔT is small and $\Delta R = (R - R_0) \ll R_0$.

- 1) Statement - 1 is true, Statement - 2 is false.
- 2) Statement - 1 is true, Statement - 2 is true ; Statement - 2 is the correct explanation of Statement - 1.
- 3) Statement - 1 is true, Statement - 2 is true ; Statement - 2 is not the correct explanation of Statement - 1 .
- 4) Statement - 1 is false, Statement - 2 is true.

Ans. 4

$$100 = R_0 [1 + \alpha (27 - 0)] \qquad 150 = R_0 [1 + \alpha (227 - 0)]$$

Solving $\alpha = 2.68 \times 10^{-3}$

\therefore Statement 1 is false

Directions : Question numbers 12 and 13 are based on the following paragraph.

A current loop ABCD is held fixed on the plane of the paper as shown in the figure. The arcs BC (radius - b) and DA (radius = a) of the loop are joined by two straight wires AB and CD. A steady current I is flowing in the loop. Angle made by AB and CD at the origin O is 30° . Another straight thin wire with steady current I_1 flowing out of the plane of the paper is kept at the origin

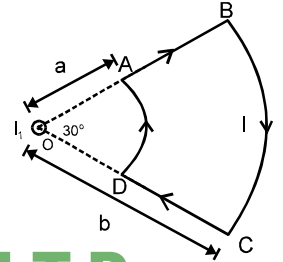

PADH EE'S TU TO RIAL PV T. LT D.

12. The magnitude of the magnetic field (B) due to the loop ABCD at the origin (O) is

- 1) Zero
- 2) $\frac{\mu_0 I (b - a)}{24 ab}$
- 3) $\frac{\mu_0 I}{4\pi} \left[\frac{b - a}{ab} \right]$
- 4) $\frac{\mu_0 I}{4\pi} \left[2(b - a) + \frac{\pi}{3}(a + b) \right]$

Ans. 2

$\vec{B}_{AB} = 0,$

$\vec{B}_{CD} = 0$

$\vec{B}_{arcBC} = \frac{\mu_0 I}{2b} \left(\frac{\pi/6}{2\pi} \right) = \frac{\mu_0 I}{24b} \otimes$

$\vec{B}_{arcAD} = \frac{\mu_0 I}{2a} \left(\frac{\pi/6}{2\pi} \right) = \frac{\mu_0 I}{24a} \odot$

$\therefore B_{net} = \frac{\mu_0 I}{24} \left[\frac{1}{a} - \frac{1}{b} \right] = \frac{\mu_0 I}{24} \left(\frac{b - a}{ab} \right)$

13. Due to the presence of the current I_1 at the origin

- 1) The forces on AB and DC are zero
- 2) The forces on AD and BC are zero

3) The magnitude of the net force on the loop is given by $\frac{I_1 I}{4\pi} \mu_0 \left[2(b - a) + \frac{\pi}{3}(a + b) \right]$

4) The magnitude of the net force on the loop is given by $\frac{\mu_0 I I_1}{24 ab} (b - a)$.

Ans. 2

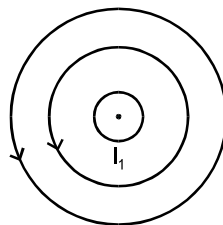

Magnetic lines will be circular as shown. Hence force on AD and BC will be zero.

14. A mixture of light, consisting of wavelength 590 nm and an unknown wavelength, illuminates Youngs double slit and gives rise to two overlapping interference patterns on the screen. The central maximum of both lights coincide. Further, it is observed that the third bright fringe of known light coincides with the 4th bright fringe of the unknown light . From this data, the wavelength of the unknown light is

- 1) 393.4 nm
- 2) 885.0 nm
- 3) 442.5 nm
- 4) 776.8 nm

Ans. 3

$$\lambda_1 = 590 \text{ nm} \quad \lambda_2 = ?$$

$$\frac{3\lambda_1 D}{d} = \frac{4\lambda_2 D}{d} \Rightarrow \lambda_2 = \frac{3\lambda_1}{4} = \frac{3 \times 590}{4} = 442.5 \text{ nm}$$

15. Two points P and Q are maintained at the potentials of 10V and -4V, respectively. The work done in moving 100 electrons from P to Q is

- 1) $-9.60 \times 10^{-17} \text{ J}$ 2) $9.60 \times 10^{-17} \text{ J}$ 3) $-2.24 \times 10^{-16} \text{ J}$ 4) $2.24 \times 10^{-16} \text{ J}$

Ans. 4

$$V_p = 10 \text{ v}$$

$$V_Q = -4 \text{ V}$$

$$W_{\text{ext}} = q(v_f - v_i) = q(v_Q - v_p) = \{-100 \times 1.6 \times 10^{-19} (-4 - 10)\} = 2.24 \times 10^{-17} \text{ J} = 2.24 \times 10^{-16} \text{ J}$$

16. The surface of a metal is illuminated with the light of 400 nm. The kinetic energy of the ejected photoelectrons was found to be 1.68 eV. The work function of the metal is ($hc = 1240 \text{ eV} \cdot \text{nm}$)

- 1) 3.09 eV 2) 1.41 eV 3) 1.51 eV 4) 1.68 eV

Ans. 2

$$\lambda = 400 \text{ nm}$$

$$KE = 1.68 \text{ eV}$$

$$KE = \frac{hc}{\lambda} - \phi \Rightarrow 1.68 \text{ eV} = \frac{1240 \text{ eV} \cdot \text{nm}}{400} - \phi \Rightarrow \phi = \frac{1240}{400} \text{ eV} - 1.68 \text{ eV} = (3.1 - 1.68) \text{ eV} = 1.42 \text{ eV}$$

17. A particle has an initial velocity of $3\hat{i} + 4\hat{j}$ and an acceleration of $0.4\hat{i} + 0.3\hat{j}$. Its speed after 10 s is

- 1) 10 units 2) $7\sqrt{2}$ units 3) 7 units 4) 8.5 units

Ans. 2

$$\vec{U} = 3\hat{i} + 4\hat{j}, \quad \vec{a} = 0.4\hat{i} + 0.3\hat{j} \quad V_x = U_x + a_x t$$

$$= 3 + 0.4 \times 10 = 7$$

$$V_y = U_y + a_y t = 4 + 0.3 \times 10 = 7$$

$$\therefore U = \sqrt{V_x^2 + V_y^2} = 7\sqrt{2} \text{ units}$$

18. A motor cycle starts from rest and accelerates along a straight path at 2 m/s^2 . At the starting point of the motor cycle there is a stationary electric siren. How far has the motor cycle gone when the driver hears the frequency of the siren at 94% of its value when the motor cycle was at rest? (Speed of sound = 330 ms^{-1})

- 1) 49 m 2) 98 m 3) 147 m 4) 196 m

Ans. 2

$$U = 0$$

$$a = 2 \text{ m/s}^2$$

Let f_0 be the frequency of siren when motor cycle was at rest

$$\therefore f = 0.94 f_0$$

$$f = \left(\frac{v - v_0}{V} \right) f_0 \Rightarrow 0.94 f_0 = \left(\frac{330 - V_0}{330} \right) f_0 \Rightarrow 310.2 = 330 - V_0 \Rightarrow V_0 = 330 - 310.2 = 19.8 \text{ m/s}$$

$$V_0^2 = u^2 + 2as \Rightarrow (19.8)^2 = 0 + 2 \times 2 \text{ s} \Rightarrow S = \frac{(19.8)^2}{4} = 98.01 \text{ m}$$

19. Consider a rubber ball freely falling from a height $h = 4.9 \text{ m}$ onto a horizontal elastic plate. Assume that the duration of collision is negligible and the collision with the plate is totally elastic. Then the velocity as a function of time and the height as a function of time will be

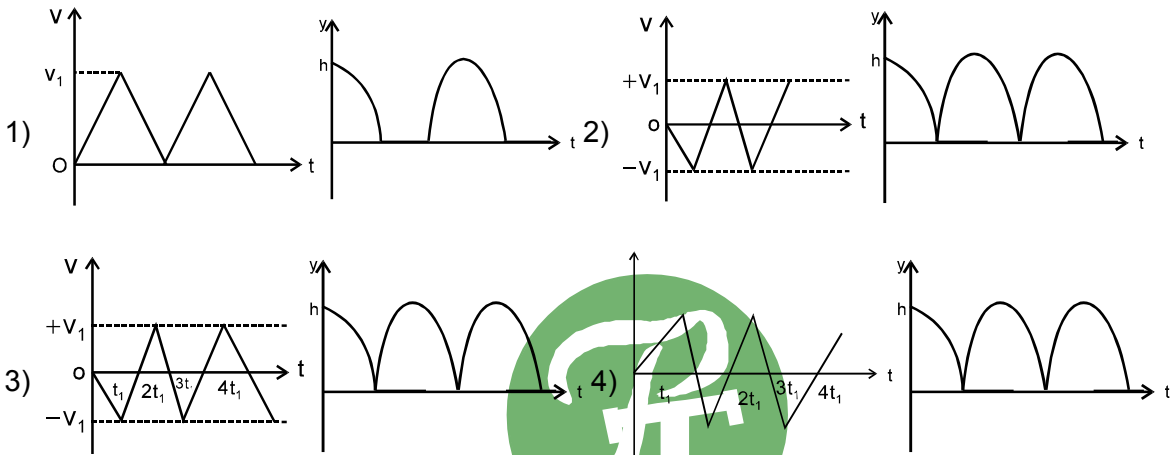

Ans. 3

20. A charge Q is placed at each of the opposite corners of a square. A charge q is placed at each of the other two corners. If the net electrical force on Q is zero, then Q/q equals

PADH EE'S TU TO RIAL PV T. LT D.

- 1) $-2/\sqrt{2}$ 2) -1 3) 1 4) $-\frac{1}{\sqrt{2}}$

Ans. 1

If Q & q have same sign
resultant cannot be zero. if Q & q have opposite sign

∴ Resultant can be zero. For zero resultant

$$|F_3| = \sqrt{F_1^2 + F_2^2} = \sqrt{2} F_1 = \sqrt{2} F_2$$

$$\Rightarrow \frac{KQ^2}{(\sqrt{2}a)^2} = \frac{\sqrt{2}KQq}{a^2}$$

$$\Rightarrow \frac{Q^2}{2^2} = \frac{\sqrt{2}KQq}{a^2}$$

$$\Rightarrow \frac{Q}{2} = q\sqrt{2}$$

$$\Rightarrow \frac{Q}{2} = 2\sqrt{2}q \quad \therefore \text{required answer is } \frac{Q}{q} = -2\sqrt{2}$$

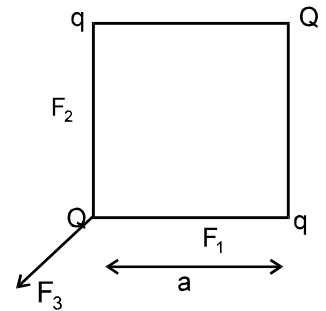
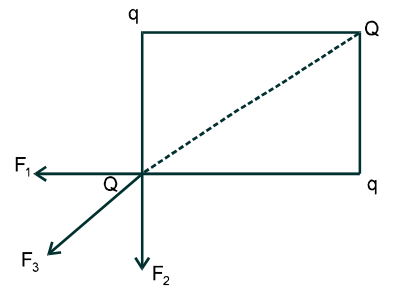

21. A long metallic bar is carrying heat from one of its ends to the other end under steady-state. The variation of temperature θ along the length x of the bar from its hot end is best described by which of the following figures ?

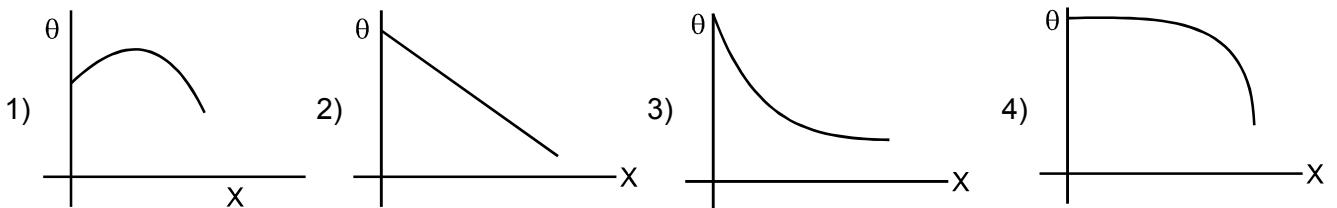

Ans. 2

$$\frac{dQ}{dt} = \frac{KA(\theta_1 - \theta)}{x} \Rightarrow \left(\frac{dQ}{dt}\right) x = KA(\theta_1 - \theta)$$

$$\Rightarrow \theta = \theta_1 - \left(\frac{dQ}{KA} \right) x \Rightarrow \theta = \theta_1 - Kx \quad k \rightarrow \text{constant}$$

22. A transparent solid cylindrical rod has a refractive index of $\frac{2}{\sqrt{3}}$. It is surrounded by air. A light ray is incident at the midpoint of one end of the rod as shown in the figure.

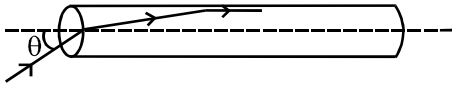

The incident angle θ which the light ray grazes along the wall of the rod is

- 1) $\sin^{-1}\left(\frac{1}{2}\right)$ 2) $\sin^{-1}\left(\frac{\sqrt{3}}{2}\right)$ 3) $\sin^{-1}\left(\frac{2}{\sqrt{3}}\right)$ 4) $\sin^{-1}\left(\frac{1}{\sqrt{3}}\right)$

Ans. 4

PADHEE'S TU T O R I A L P V T. L T D.



$$1 \sin \theta = \mu \sin r$$

$$\mu \sin \theta_c = 1 \sin 90^\circ \Rightarrow \sin \theta_c = \frac{1}{\mu} = \frac{\sqrt{3}}{2}$$

$$\therefore \theta_c = 90 - r \Rightarrow \sin(90 - r) = \frac{\sqrt{3}}{2} \Rightarrow \cos r = \frac{\sqrt{3}}{2} \Rightarrow \sin r = \frac{1}{2}$$

$$\therefore \sin \theta = \mu \sin r = \frac{2}{\sqrt{3}} \times \frac{1}{2} = \frac{1}{\sqrt{3}} \quad \therefore \theta = \sin^{-1}\left(\frac{1}{\sqrt{3}}\right)$$

23. Three sound waves of equal amplitudes have frequencies $(v - 1), v, (v + 1)$. They *superpose* to give beats. The number of beats produced per second will be

- 1) 4 2) 3 3) 2 4) 1

Ans. 3

24. The height at which the acceleration due to gravity becomes $\frac{g}{9}$ (where g = the acceleration due to gravity on the surface of the earth) in terms of R , the radius of the earth, is

- 1) $2R$ 2) $\frac{R}{\sqrt{2}}$ 3) $\frac{R}{2}$ 4) $\sqrt{2} R$

Ans. 1

$$g' = \frac{GM}{(R+h)^2} = \frac{GM}{R^2 \left(1 + \frac{h}{R}\right)^2} \Rightarrow g' = \frac{g}{\left(1 + \frac{h}{R}\right)^2} \Rightarrow \frac{g}{9} = \frac{g}{\left(1 + \frac{h}{R}\right)^2} \Rightarrow \left(1 + \frac{h}{R}\right)^2 = 9 \Rightarrow 1 + \frac{h}{R} = 3$$

$$\Rightarrow \frac{h}{R} = 2 \Rightarrow h = 2R$$

25. Two wires are made of the same material and have the same volume. However wire 1 has cross-sectional area A and wire 2 has cross-sectional area $3A$. If the length of wire 1 increases by Δx on applying force F , how much force is needed to stretch wire 2 by the same amount ?

- 1) F 2) $4F$ 3) $6F$ 4) $9F$

Ans. 4

∴ volume is constant

$$Al = 3Al'$$

$$\Rightarrow l' = l/3$$

$$\frac{F}{A} = Y \frac{\Delta x}{l} \quad \dots\dots(1)$$

$$\frac{F'}{3A} = Y \frac{\Delta x}{l/3} = Y \frac{3\Delta x}{l} \quad \dots\dots(2)$$

$$\Rightarrow \frac{\frac{F}{A}}{\frac{F'}{3A}} = \frac{1}{3} \Rightarrow \frac{F}{A} \times \frac{3A}{F'} = \frac{1}{3} \Rightarrow F' = 9F$$

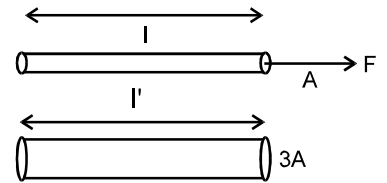

26. In an experiment the angles are required to be measured using an instrument. 29 divisions of the main scale exactly coincide with the 30 divisions of the vernier scale. If the smallest division of the main scale is half - a-degree ($= 0.5^\circ$), then the least count of the instrument is

- 1) One minute 2) Half minute 3) One degree 4) Half degree

Ans. 1

$$L.C = 1MSD - 1VSD \quad \dots\dots(1)$$

$$29 \text{ MSD} = 30 \text{ VSD}$$

$$1VSD = \frac{29}{30} \text{ MSD}$$

$$LC = \left(1 - \frac{29}{30}\right) \text{MSD} = \frac{1}{30} \times 0.5^\circ = \left(\frac{1}{60}\right)^\circ = 1 \text{ minute}$$

27.

An inductor of inductance $L = 400 \text{ mH}$ and resistors of resistances $R_1 = 2 \Omega$ and $R_2 = 2 \Omega$ are connected to a battery of emf 12 V as shown in the figure. The internal resistance of the battery is negligible. The switch S is closed at $t = 0$. The potential drop across L as a function of time is

- 1) $6e^{-5t} \text{ V}$ 2) $\frac{12}{t} e^{-3t} \text{ V}$ 3) $6\left(1 - e^{-t/0.2}\right) \text{ V}$ 4) $12e^{-5t} \text{ V}$

Directions : Question numbers 28, 29 and 30 are based on the following paragraph.

Two moles of helium gas are taken over the cycle ABCDA, as shown in the P-T diagram

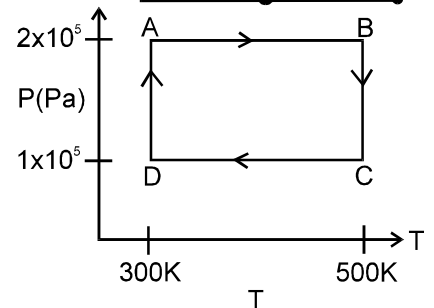
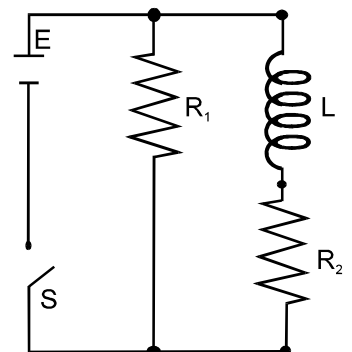

Ans. 4

$$I = I_0(1 - e^{-t/\tau})$$

$$\therefore V_2 = L \frac{dI}{dt} = L \frac{I_0}{\tau} e^{-t/\tau}$$

where I_0 is the current at $t = \infty$

At $t = \infty$ inductor gets as short circuit

$$\therefore I_0 = \frac{E}{R_2} \text{ and } \tau = \frac{L}{R_2} = \frac{400 \times 10^{-3}}{2} = 200 \times 10^{-3} = 0.2$$

$$\therefore V_2 = \frac{LEe^{-t/\tau}}{R_2} = Ee^{-t/\tau} = 12e^{-\frac{t}{0.2}} = 12e^{-5t}$$

28. Assuming the gas to be ideal the work done on the gas in taking it from A to B is
 1) 200 R 2) 300 R 3) 400 R 4) 500 R

Ans. 3

Process A – B → Pressure is constant

$$\therefore W = P\Delta V = nR\Delta T = 2 \times R(500 - 300) = 400R$$

29. The work done on the gas in taking it from D to A is

- 1) - 414 R 2) + 414 R 3) - 690 R 4) + 690 R

Ans. 1

Process D – A → Temp is constant

$$\therefore W = 2.303 nRT \log_{10} \frac{V_A}{V_D} = 2.303 nRT \log_{10} \frac{P_D}{P_A} = 2.303 \times 2 \times R \times 300 \log_{10} \frac{10^5}{2 \times 10^5}$$

$$= 1381.8 \log_{10} \frac{1}{2} = -1381.8 \log_{10} 2 = -415.92R$$

30. The net work done on the gas in the cycle ABCDA is

- 1) Zero 2) 276 R 3) 1076 R 4) 1904 R

Ans. 2

$$W_{\text{net}} = W_{AB} + W_{BC} + W_{CD} + W_{DA} \quad W_{CD} = nR\Delta T = -400R = -400R$$

$$W_{BC} = 2.303 nRT \log_{10} \frac{P_B}{P_C} = 2.303 \times 2R \times 500 \log_{10} 2 = 693.2R$$

$$\therefore W_{\text{net}} = 400R + 693.2R - 400R - 415.92R = 277.28R$$

CHEMISTRY

PART B

31. Knowing that the chemistry of lanthanoids (Ln) is dominated by its +3 oxidation state, which of the following statement is incorrect ?

- (1) Because of the large size of the Ln (III) ions the bonding in its compounds is predominantly ionic in character
 (2) The ionic sizes of Ln(III) decrease in general with increasing atomic number
 (3) Ln (III) compounds are generally colourless
 (4) Ln (III) hydroxides are mainly basic in character .

Ans. 3

Ln (III) compounds are usually coloured

32. A liquid was mixed with ethanol and a drop of concentrated H_2SO_4 was added . A compound with a fruity smell was formed . The liquid was

- (1) CH_3OH (2) $HCHO$ (3) CH_3COCH_3 (4) CH_3COOH

Ans. 4



33. Arrange the carbanions $(CH_3)_3\bar{C}$, $\bar{C}Cl_3$, $(CH_3)_2\bar{C}H$, $C_6H_5\bar{C}H_2$ in order of their decreasing stability

- (1) $C_6H_5\bar{C}H_2 > \bar{C}Cl_3 > (CH_3)_3\bar{C} > (CH_3)_2\bar{C}H$ (2) $(CH_3)_2\bar{C}H > \bar{C}Cl_3 > C_6H_5\bar{C}H_2 > (CH_3)_3\bar{C}$
 (3) $\bar{C}Cl_3 > C_6H_5\bar{C}H_2 > (CH_3)_2\bar{C}H > (CH_3)_3\bar{C}$ (4) $(CH_3)_3\bar{C} > (CH_3)_2\bar{C}H > C_6H_5\bar{C}H_2 > \bar{C}Cl_3$

Ans. 3

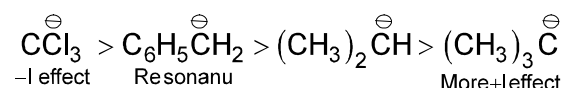

34. The alkene that exhibits geometrical isomerism is

- (1) propene (2) 2-methyl propane (3) 2-butene (4) 2-methyl-2-butene

Ans. 3

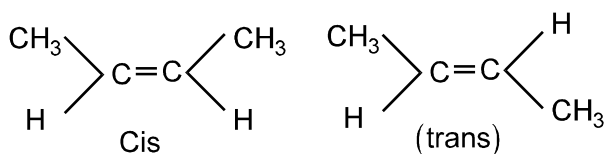

35. In which of the following arrangements the sequence is not strictly according to the property written against it ?

- (1) $\text{CO}_2 < \text{SiO}_2 < \text{SnO}_2 < \text{PbO}_2$ increasing oxidising power .
 (2) $\text{HF} < \text{HCl} < \text{HBr} < \text{HI}$: increasing acid strength
 (3) $\text{NH}_3 < \text{PH}_3 < \text{AsH}_3 < \text{SbH}_3$: increasing basic strength
 (4) $\text{B} < \text{C} < \text{O} < \text{N}$: increasing first ionization enthalpy.

Ans. 3

Basic nature decreases down the group

36. The major product obtained on interaction of phenol with sodium hydroxide and carbon dioxide is

- (1) benzoic acid (2) salicylaldehyde (3) salicylic acid (4) phthalic acid

Ans. 3

Kolbe's reaction

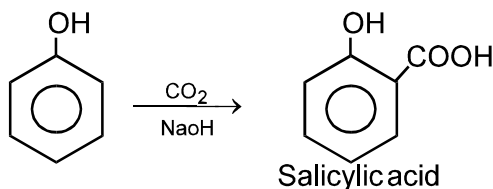

37. Which of the following statements is incorrect regarding physisorptions

- (1) It occurs because of van der Waal's forces
 (2) More easily liquefiable gases are adsorbed readily
 (3) Under high pressure it results into multi molecular layer on adsorbent surface
 (4) Enthalpy of adsorption ($\Delta H_{\text{adsorption}}$) is low and positive.

Ans. 4

Physisorptions are usually exothermic reaction, hence, $\Delta H = -ve$

38. Which of the following on heating with aqueous KOH produces acetaldehyde ?

- (1) CH_3COCl (2) $\text{CH}_3\text{CH}_2\text{Cl}$ (3) $\text{CH}_2\text{ClCH}_2\text{Cl}$ (4) CH_3CHCl_2

Ans. 4

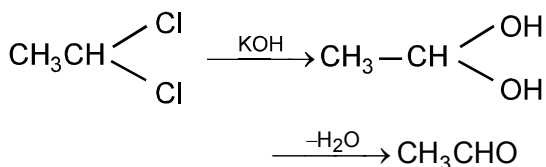

39. In an atom, an electron is moving with a speed of 600 m/s with an accuracy of 0.005% . Certainty with which the position of the electron can be located is ($h = 6.6 \times 10^{-34} \text{ kg m}^2\text{s}^{-1}$, mass of electron, $e_m = 9.1 \times 10^{-31} \text{ kg}$) :

- (1) $1.52 \times 10^{-4} \text{ m}$ (2) $5.10 \times 10^{-3} \text{ m}$ (3) $1.92 \times 10^{-3} \text{ m}$ (4) $3.84 \times 10^{-3} \text{ m}$

Ans. 3

$$\Delta x \times \Delta V = \frac{h}{4\pi m}$$

$$\Delta x \times 600 \times 5 \times 10^{-3} \times 10^{-2} = \frac{6.62 \times 10^{-34}}{4 \times 3.1 \times 9.1 \times 10^{-31}}$$

or $\Delta x = 1.92 \times 10^{-3} \text{ m}$

40. In a fuel cell methanol is used as fuel and oxygen gas is used as an oxidizer. The reaction is $\text{CH}_3\text{OH}(\text{l}) + \frac{3}{2}\text{O}_2(\text{g}) \rightarrow \text{CO}_2(\text{g}) + 2\text{H}_2\text{O}(\text{l})$

At 298 K standard Gibb's energies of formation for $\text{CH}_3\text{OH}(\text{l})$, $\text{H}_2\text{O}(\text{l})$ and $\text{CO}_2(\text{g})$ are -166.2, -237.2 and -394.4 kJ mol⁻¹ respectively. If standard enthalpy of combustion of methanol is -726 kJ mol⁻¹, efficiency of the fuel cell will be

- (1) 80% (2) 87% (3) 90% (4) 97%

Ans. 4



$$\Delta H = -726 \text{ hence } \eta = \frac{\Delta G}{\Delta H} = -\frac{702.6}{726} = 97\%$$

41. Two liquids X and Y form an ideal solution. At 300K, vapour pressure of the solution containing 1 mol of X and 3 mol of Y is 550 mmHg. At the same temperature, if 1 mol of Y is further added to this solution, vapour pressure of the solution increases by 10 mmHg. Vapour pressure (in mmHg) of X and Y in their pure states will be respectively :

- (1) 200 and 300 (2) 300 and 400 (3) 400 and 600 (4) 500 and 600

Ans. 3

$$X_x = \frac{1}{4} \quad X_y = \frac{3}{4} \quad P_T = P_x^0 X_x + P_y^0 X_y$$

$$550 = \frac{1}{4} \times P_x^0 + \frac{3}{4} P_y^0 \dots\dots\dots(1)$$

$$560 = \frac{1}{5} \times P_x^0 + \frac{4}{5} P_y^0$$

$$P_x^0 = 400, P_y^0 = 600$$

42. The half life period of a first order chemical reaction is 6.93 minutes. The time required for the completion of 99% of the chemical reaction will be (log2 = 0.301)

- (1) 230.3 minutes (2) 23.03 minutes (3) 46.06 minutes (4) 460.6 minutes

Ans. 3

$$K = \frac{0.693}{H_2} = \frac{0.693}{6.93} = 0.1$$

$$K = \frac{2.303}{t} \log \frac{100}{100 - 99} \text{ or } t = \frac{2.303}{0.1} \times \log 100 = \frac{2.303 \times 2}{0.1} = 46.06 \text{ min}$$

43. Given $E_{\text{Fe}^{3+}/\text{Fe}}^0 = -0.036\text{V}$, $E_{\text{Fe}^{2+}/\text{Fe}}^0 = -0.439\text{V}$. The value of standard electrode potential for the change,

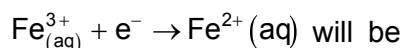

- (1) -0.072V (2) 0.385V (3) 0.770 V (4) -0.270 V

Ans. 3

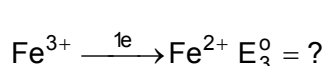
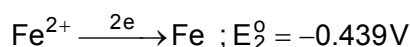
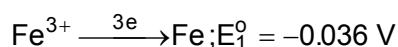

$$E_3^0 = \frac{n_1 \times E_1^0 - n_2 E_2^0}{n_3}$$

$$= \frac{-0.036 \times 3 + 0.439 \times 2}{1} = 0.77V$$

44. On the basis of the following thermochemical data ($\Delta_f G^\circ H_{(aq)}^+ = 0$)

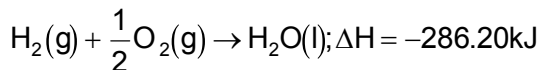
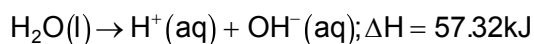

The value of enthalpy of formation of OH^- ion at $25^\circ C$ is

- (1) -22.88 kJ (2) -228.88 kJ (3) $+228.88 \text{ kJ}$ (4) -343.52 kJ

Ans. 2

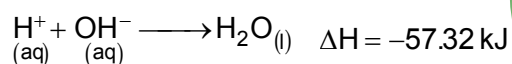

$$\Delta H = \Delta_f H_{H_2O} - \Delta_f H(OH^-) - 57.32 = -286.2 - \Delta_f H_{OH^-}$$

$$\Delta_f H_{OH^-} = -228.88 \text{ kJ}$$

45. Copper crystallises in fcc with a unit cell length of 361 pm. What is the radius of copper atom?

- (1) 108 pm (2) 127 pm (3) 157 pm (4) 181 pm

Ans. 2

$$r = \frac{a}{2\sqrt{2}} = \frac{361}{2\sqrt{2}} = 127.25$$

46. Which of the following has an optical isomer?

- 1) $[CO(NH_3)_3Cl]^+$ 2) $[CO(en)(NH_3)_2]^{2+}$ 3) $[CO(H_2O)_4(en)]^{3+}$ 4) $[CO(en)_2(NH_3)_2]^{3+}$

Ans. 4

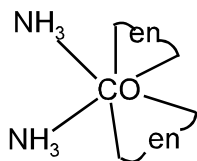

(active)

47. Solid $Ba(NO_3)_2$ is gradually dissolved in a $1.0 \times 10^{-4} M$ Na_2CO_3 solution. At what concentration of Ba^{2+} will a precipitate begin to form?

(K_{sp} for $BaCO_3 = 5.1 \times 10^{-9}$):

- 1) $4.1 \times 10^{-5} M$ 2) $5.1 \times 10^{-5} M$ 3) $8.1 \times 10^{-8} M$ 4) $8.1 \times 10^{-7} M$

Ans. 2

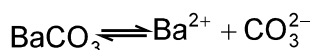

$$K_{sp} = [Ba^{2+}][CO_3^{2-}] \quad [Ba^{2+}] = \frac{K_{sp}}{[CO_3^{2-}]} = \frac{5.1 \times 10^{-9}}{1 \times 10^{-4}} = 5.1 \times 10^{-5}$$

48. Which one of the following reactions of Xenon compounds is not feasible?

- 1) $XeO_3 + 6HF \rightarrow XeF_6 + 3H_2O$ 2) $3XeF_4 + 6H_2O \rightarrow 2Xe + XeO_3 + 12HF + 1.5O_2$
 3) $2XeF_2 + 2H_2O \rightarrow 2Xe + 4HF + O_2$ 4) $XeF_6 + RbF \rightarrow Rb[XeF_7]$

Ans. 1

49. Using MO theory predict which of the following species has the shortest bond length?

- (1) O_2^+ (2) O_2 (3) O_2^- (4) O_2^{2-}

Ans. 1

$$\text{Bond length} \propto \frac{1}{\text{B.O}}$$

$$\text{B.O of } \text{O}_2^{2+} = 3, \quad \text{O}_2^+ = 2.5$$

$$\text{O}_2^- = 1.5, \quad \text{O}_2^{2-} = -1$$

50. In context with the transition elements, which of the following statements is incorrect?

- 1) In addition to the normal oxidation states, the zero oxidation state is also shown by these elements in complexes.
- 2) In the highest oxidation states, the transition metal show basic character and form cationic complexes.
- 3) In the highest oxidation state of the first five transition elements (Sc to Mn), all the 4s and 3d electrons are used for bonding
- 4) Once the d^5 configuration is exceeded, the tendency to involve all the 3d electrons in bonding decreases.

Ans. 2

As Oxidation state increases acidic nature increases

51. Calculate the wavelength (in nanometer) associated with a proton moving at $1.0 \times 10^3 \text{ ms}^{-1}$.(Mass of proton = $1.67 \times 10^{-27} \text{ kg}$ and $h = 6.63 \times 10^{-34} \text{ Js}$):

- 1) 0.032nm
- 2) 0.40nm
- 3) 2.5 nm
- 4) 14.0 nm

Ans. 2

$$\lambda = \frac{h}{mv} = \frac{6.63 \times 10^{-34}}{1.67 \times 10^{-27} \times 1 \times 10^3} = 0.4 \text{ nm}$$

52. A binary liquid solution is prepared by mixing n-heptane and ethanol. Which one of the following statements is correct regarding the behaviour of the solution?

- 1) The solution formed is an ideal solution
- 2) The solution is non-ideal, showing +ve deviation from Raoult's Law
- 3) The solution is non-ideal, showing -ve deviation for Raoult's Law.
- 4) n-heptane shows +ve deviation while ethanol shows -ve deviation from Raoult's Law.

Ans. 2

n-heptane and ethanol show +ve deviation

53. The number of stereoisomers possible for a compound of the molecular formula

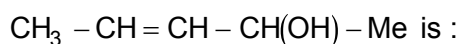

- 1) 3
- 2) 2
- 3) 4
- 4) 6

Ans. 3

Cis trans d and l
total isomers = 4

54. The IUPAC name of neopentane is

- 1) 2-methylbutane
- 2) 2,2-dimethylpropane
- 3) 2-methylpropane
- 4) 2,2-dimethylbutane

Ans. 2

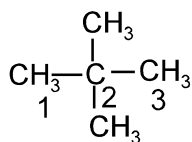

55. The set representing the correct order of ionic radius is

- 1) $\text{Li}^+ > \text{Be}^{2+} > \text{Na}^+ > \text{Mg}^{2+}$
- 2) $\text{Na}^+ > \text{Li}^+ > \text{Mg}^{2+} > \text{Be}^{2+}$
- 3) $\text{Li}^+ > \text{Na}^+ > \text{Mg}^{2+} > \text{Be}^{2+}$
- 4) $\text{Mg}^{2+} > \text{Be}^{2+} > \text{Li}^+ > \text{Na}^+$

Ans.2# Question is wrong

Correct answer is : $\text{Na}^+ > \text{Mg}^{2+} > \text{Li}^+ > \text{Be}^{2+}$

56. The two functional groups present in a typical carbohydrate are :

- 1) $-\text{OH}$ and $-\text{COOH}$
- 2) $-\text{CHO}$ and $-\text{COOH}$
- 3) $>\text{C}=\text{O}$ and $-\text{OH}$
- 4) $-\text{OH}$ and $-\text{CHO}$

Ans. 3

Carbohydrate usually contains $-\overset{\text{O}}{\parallel}{\text{C}}-$ and $-\text{OH}$ group

57. The bond dissociation energy of B-F in BF_3 is 646 kJ mol^{-1} whereas that of C-F in CF_4 is 515 kJ mol^{-1} . The correct reason for higher B-F bond dissociation energy as compared to that of C-F is :

- 1) smaller size of B-atom as compared to that of C-atom
- 2) Stronger σ bond between B and F in BF_3 as compared to that between C and F in CF_4
- 3) Significant $p\pi - p\pi$ interaction between B and F in BF_3 whereas there is no possibility of such interaction between C and F in CF_4
- 4) Lower degree of $p\pi - p\pi$ interaction between B and F in BF_3 than that between C and F in CF_4

Ans. 3

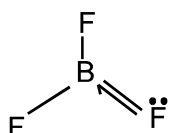

back bonding is possible due to vacant p-orbital of B

58. In Cannizzaro reaction given below $2\text{PhCHO} \xrightarrow{:\text{OH}^-} \text{PhCH}_2\text{OH} + \text{PhCO}_2^-$

the slowest step is :

- 1) the attack of $:\text{OH}^-$ at the carboxyl group
- 2) the transfer of hydride to the carbonyl group
- 3) the abstraction of proton from the carboxylic group.
- 4) the deprotonation of PhCH_2OH

Ans. 2

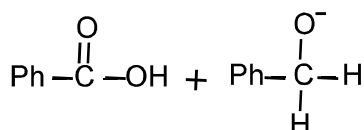
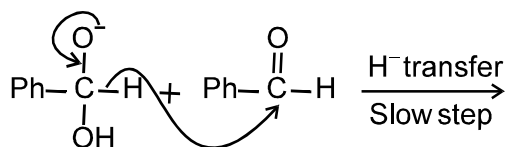
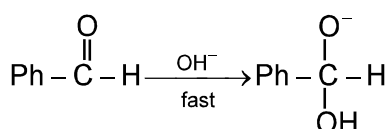

59. Which of the following pairs represents linkage isomers ?

- (1) $[\text{Cu}(\text{NH}_3)_4][\text{PtCl}_4]$ and $[\text{Pt}(\text{NH}_3)_4][\text{CuCl}_4]$
- (2) $[\text{Pd}(\text{PPh}_3)_2(\text{NCS})_2]$ and $[\text{Pd}(\text{PPh}_3)_2(\text{SCN})_2]$
- (3) $[\text{CO}(\text{NH}_3)_5\text{NO}_3]\text{SO}_4$ and $[\text{CO}(\text{NH}_3)_5\text{SO}_4]\text{NO}_3$
- (4) $[\text{PtCl}_2(\text{NH}_3)_4]\text{Br}_2$ and $[\text{PtBr}_2(\text{NH}_3)_4]\text{Cl}_2$

Ans. 2

Either N or S can Co-ordinate

- 1) A is true and B is false
- 2) A is false and B is true
- 3) both A and B are true
- 4) both A and B are false

Ans : 3

$$\cos(\beta - \gamma) + \cos(\gamma - \alpha) + \cos(\alpha - \beta) = -\frac{3}{2}$$

$$2(\cos(\beta - \gamma) + \cos(\gamma - \alpha) + \cos(\alpha - \beta)) = -3$$

$$\Rightarrow (\cos \alpha + \cos \beta + \cos \gamma)^2 + (\sin \alpha + \sin \beta + \sin \gamma)^2 = 0$$

$$\Rightarrow \cos \alpha + \cos \beta + \cos \gamma = 0$$

and

$$\Rightarrow \sin \alpha + \sin \beta + \sin \gamma = 0$$

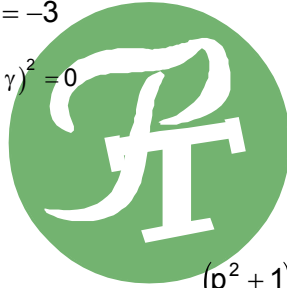

65. The lines $p(p^2 + 1)x - y + q = 0$ and $(p^2 + 1)^2 x + (p^2 + 1)y + 2q = 0$ are perpendicular to a common line for :

- 1) no value of p
- 2) exactly one value of p
- 3) exactly two values of p
- 4) more than two values of p

Ans: 2

$$p(p^2 + 1)x - y + q = 0$$

$$(p^2 + 1)^2 x + (p^2 + 1)y + 2q = 0 \text{ are must be parallel}$$

$$= \frac{p(p^2 + 1)}{(p^2 + 1)^2} = \frac{-1}{p^2 + 1}$$

$$\Rightarrow p = -1$$

66. If A, B and C are three sets such that

$$A \cap B = A \cap C \text{ and } A \cup B = A \cup C, \text{ then :}$$

- 1) A = B
- 2) A = C
- 3) B = C
- 4) A ∩ B = φ

Ans : 3

$$A \cup B = A \cup C$$

$$A \cap B = A \cap C \text{ their is only one case possible } B = C$$

67. If $\vec{u}, \vec{v}, \vec{w}$ are non-coplanar vectors and p, q are real numbers, then the quality

$$[3\vec{u} \ p\vec{v} \ p\vec{w}] - [p\vec{v} \ \vec{w} \ q\vec{u}] - [2\vec{w} \ q\vec{v} \ q\vec{u}] = 0 \text{ holds for :}$$

- 1) exactly one value of (p, q)
- 2) exactly two value of (p,q)
- 3) more then two but not all values of (p, q)
- 4) all values of (p, q)

Ans : 1

$$[3\vec{u} \ p\vec{v} \ p\vec{w}] - [p\vec{v} \ \vec{w} \ q\vec{u}] - [2\vec{w} \ q\vec{v} \ q\vec{u}] = 0$$

$$3p^2[\vec{u} \ \vec{v} \ \vec{w}] - pq[\vec{v} \ \vec{w} \ \vec{u}] - 2q^2[\vec{w} \ \vec{v} \ \vec{u}] = 0$$

$$3p^2 - pq + 2q^2 = 0$$

Only one case possible if p = 0 and q = 0

68. Let the line $\frac{x-2}{3} = \frac{y-1}{-5} = \frac{z+2}{2}$ lie in the plane $x + 3y - \alpha z + \beta = 0$. Then (α, β) equals :
- 1) (6, -17) 2) (-6, 7) 3) (5, -15) 4) (-5, 5)

Ans : 2

If the line $\frac{x-2}{3} = \frac{y-1}{-5} = \frac{z+2}{2}$ lie in the plane $x + 3y - \alpha z + \beta = 0$.

Then $1.3 + 3.(-5) - 2.\alpha = 0 \Rightarrow \alpha = -6$

$2 + 3 + 2\alpha + \beta = 0 \Rightarrow \beta = 7$

69. From 6 different novels and 3 different dictionaries, 4 novels and 1 dictionary are to be selected and arranged in a row on a shelf so that the dictionary is always in the middle. Then the number of such arrangements is :

- 1) less than 500 2) at least 500 but less than 750
3) at least 750 but less than 1000 4) at least 1000

Ans : 4

The total number of arrangement is ${}^6C_4 \times {}^3C_1 \times 4! = 1080$

70. $\int_0^{\pi} [\cot x] dx$, where $[.]$ denotes the greatest integer function, is equal to

- 1) $\frac{\pi}{2}$ 2) 1 3) -1 4) $-\frac{\pi}{2}$

Ans : 3

71. For real x , let $f(x) = x^3 + 5x + 1$, then

- 1) f is one-one but not onto \mathbb{R} 2) f is onto \mathbb{R} but not one-one
3) f is one-one and onto \mathbb{R} 4) f is neither one-one nor onto \mathbb{R}

Ans: 3

If $f(x) = x^3 + 5x + 1$

then $f'(x) = 3x^2 + 5 > 0$ then $f(x)$ increasing which is one-one.

$f(x)$ is cubic which is onto.

72. In a binomial distribution $B\left(n, p = \frac{1}{4}\right)$, if the probability of at least one success is greater than or equal to

$\frac{9}{10}$, then n is greater than :

- 1) $\frac{1}{\log_{10}^4 - \log_{10}^3}$ 2) $\frac{1}{\log_{10}^4 + \log_{10}^3}$ 3) $\frac{9}{\log_{10}^4 - \log_{10}^3}$ 4) $\frac{4}{\log_{10}^4 - \log_{10}^3}$

Ans: 1

$1 - p(x=0) > \frac{9}{10} \Rightarrow 1 - {}^n C_0 (1/4)^0 (0/4)^n > \frac{9}{10} \Rightarrow \frac{1}{10} > \left(\frac{3}{4}\right)^n \Rightarrow$ Taking logarithm

We get $n > \frac{1}{\log_{10}^4 - \log_{10}^3}$

73. If P and Q are the points of intersection of the circles $x^2 + y^2 + 3x + 7y + 2p - 5 = 0$ and $x^2 + y^2 + 2x + 2y - p^2 = 0$, then there is a circle passing through P, Q and (1, 1) for :

- 1) all values of p
3) all except two values of p

- 2) all except one value of p
4) exactly one value of p

Ans : 3

Now family of circle passing through p,q is $x^2 + 3x + 7y + 2p - 5 + K(x^2 + y^2 + 2x + 2y - p^2) = 0$

Putting (1, 1)

We get $k = \frac{7+2p}{p^2-6} \Rightarrow p \neq \pm\sqrt{6}$

74. The projections of a vector on the three coordinate axis are 6, -3, 2 respectively. The direction cosines of the vector are :

- 1) 6, -3, 2 2) $\frac{6}{5}, \frac{-3}{5}, \frac{2}{5}$ 3) $\frac{6}{7}, \frac{-3}{7}, \frac{2}{7}$ 4) $\frac{-6}{7}, \frac{-3}{7}, \frac{2}{7}$

Ans : 3

The direction cosine of the vector

$\frac{6}{\sqrt{6^2 + (-3)^2 + 2^2}}, \frac{-3}{\sqrt{6^2 + (-3)^2 + 2^2}}, \frac{2}{\sqrt{6^2 + (-3)^2 + 2^2}} \Rightarrow \frac{6}{7}, \frac{-3}{7}, \frac{2}{7}$

75. If $\left|z - \frac{4}{z}\right| = 2$, then the maximum value of $|z|$ is equal to

- 1) $\sqrt{3} + 1$ 2) $\sqrt{5} + 1$ 3) 2 4) $2 + \sqrt{2}$

Ans : 2

$|z| = \left|z - \frac{4}{z} + \frac{4}{z}\right| \leq \left|z - \frac{4}{z}\right| + \left|\frac{4}{z}\right|$

$|z| \leq 2 + \frac{4}{|z|}$

$|z|^2 - 2|z| \leq 4 \Rightarrow |z| \leq 1 + \sqrt{5}$

76. Three distinct point A, B and C are given in the 2 - dimensional coordinate plane such that the ratio of the distance of any one of them from the point (1, 0) to the distance from the point (-1, 0) is equal to $\frac{1}{3}$. Then the circumcenter of the triangle ABC is at the point.

- 1) (0, 0) 2) $\left(\frac{5}{4}, 0\right)$ 3) $\left(\frac{5}{2}, 0\right)$ 4) $\left(\frac{5}{3}, 0\right)$

Ans : 2

$(x-1)^2 + y^2 = \frac{1}{9}((x+1)^2 + y^2) \Rightarrow x^2 + y^2 - \frac{5}{2}x + 1 = 0$ centre (5/4, 0)

77. The remainder left out when $8^{2n} - (62)^{2n+1}$ is divided by 9 is :

- 1) 0 2) 2 3) 7 4) 8

Ans : 2

$8^{2n} - (62)^{2n+1} = (9-1)^{2n} - (63-1)^{2n+1}$
 $= \binom{2n}{0} 9^n - \binom{2n}{1} 9^{n-1} + \dots + \binom{2n}{2n} (-1)^{2n+1}$
 $= \binom{2n+1}{0} (63)^{2n+1} - \binom{2n+1}{2n} (63)^{2n} + \dots + (-1)^{2n+1}$

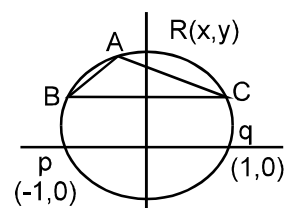

= 9M + 2 where m is an integer

78. The ellipse $x^2 + 4y^2 = 4$ is inscribed in a rectangle aligned with the coordinate axes, which is in turn inscribed in another ellipse that passes through the point (4, 0). Then the equation of the ellipse is :

- 1) $x^2 + 16y^2 = 16$ 2) $x^2 + 12y^2 = 16$ 3) $4x^2 + 48y^2 = 48$ 4) $4x^2 + 64y^2 = 48$

Ans : 2

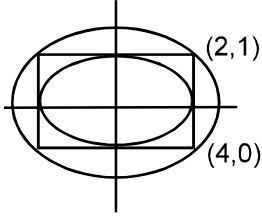

$x^2 + 12y^2 = 16$ is the only answer satisfy (4, 0) and (2, 1)

79. The sum to infinity of the series $1 + \frac{2}{3} + \frac{6}{3^2} + \frac{10}{3^3} + \frac{14}{3^4} + \dots$ is :

- 1) 2 2) 3 3) 4 4) 6

Ans : 2

$$1 + \frac{2}{3} + \frac{6}{3^2} + \frac{10}{3^3} + \frac{14}{3^4} + \dots = 1 + \frac{1}{3} \left\{ 2 + 6 \times \frac{1}{3} + 10 \times \frac{1}{3^2} + \dots \right\} = 1 + \frac{1}{3} (3 + 3) = 3$$

80. The differential equation which represents the family of curves $y = c_1 e^{c_2 x}$, where c_1 and c_2 are arbitrary constants, is

- 1) $y' = y^2$ 2) $y'' = y'y$ 3) $yy'' = y'$ 4) $yy'' = (y')^2$

Ans : 4

$$y = c_1 e^{c_2 x}, \quad y' = c_1 c_2 e^{c_2 x} \quad y'' = c_1 c_2^2 e^{c_2 x}$$

$$\text{Now } (y')^2 = c_1^2 c_2^2 (e^{c_2 x})^2 = yy''$$

81. One ticket is selected at random from 50 tickets numbered 00, 01, 02, ..., 49. Then the probability that the sum of the digits on the selected tickets is 8, given that the product of these digits is zero, equals :

- 1) $\frac{1}{14}$ 2) $\frac{1}{7}$ 3) $\frac{5}{14}$ 4) $\frac{1}{50}$

Ans : 1

The ticket number whose the product of the digit are zero are { 00, 01, 02, 03, 04, 05, 06, 07, 08, 09, 10, 20, 30, 40 }

There are 14 cases.

There is only one case sum of digit is 8. Required probability $\frac{1}{14}$.

82. Let y be an implicit function of x defined by $x^{2x} - 2x^x \cot y - 1 = 0$. Then $y'(1)$ equals :

- 1) -1 2) 1 3) $\log 2$ 4) $-\log 2$

Ans : 1

If $x = 1$ then $\cot y = 0$, Now $x^{2x} - 1 = 2x^x \cot y$

$$e^{2x \log x} - 1 = 2e^{x \log x} \cot y \Rightarrow e^{2x \log x} (2 + 2 \log x)$$

$$\Rightarrow e^{2x \log x} (2 + 2 \log x)$$

$$= 2e^{x \log x} (-\operatorname{cosec}^2 y) \frac{dy}{dx} + 2 \cot y e^{x \log x} (1 + \log x)$$

Put $x = 1$ and $\cot y = 0$ we get $\frac{dy}{dx} = -1$

83. The area of the region bounded by the parabola $(y - 2)^2 = x - 1$ then tangent to the parabola at the point $(2, 3)$ and the x-axis is :

- 1) 3 2) 6 3) 9 4) 12

Ans: 3

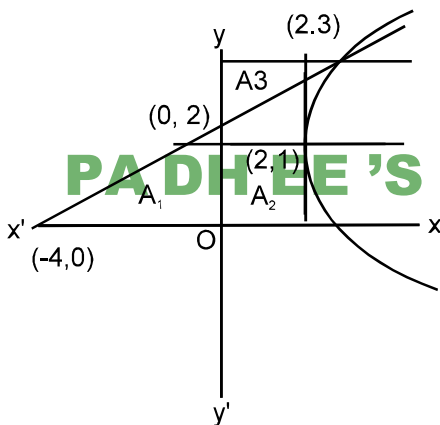

PADHEE'S TUTORIAL PVT. LTD.

$$\begin{aligned} \text{Required Area} &= A_1 + A_2 - A_3 \\ &= \frac{1}{2} \times 4 \times 2 - \int_0^3 ((y - 2)^2 + 1) dy - \frac{1}{2} \times 2 \times 1 \\ &= 9 \end{aligned}$$

84. Given $P(x) = x^4 + ax^3 + bx^2 + cx + d$ such that $x = 0$ is the only real root of $P'(x) = 0$. If

$P(-1) < P(1)$, then in the interval $[-1, 1]$:

- 1) $P(-1)$ is the minimum and $P(1)$ is the maximum of P
- 2) $P(-1)$ is not minimum but $P(1)$ is the maximum of P
- 3) $P(-1)$ is the minimum but $P(1)$ is not the maximum of P
- 4) neither $P(-1)$ is the minimum nor $P(1)$ is the maximum of P

Ans : 2

As function is of even degree. Hence at $x = 0$ minima occur

for $x \in [-1, 0)$ $f(x)$ is decreasing and for $x \in [0, 1]$ $f(x)$ is increasing

Maximum value is either $P(-1)$ or $P(1)$ but $P(-1) < P(1)$. Hence $P(1)$ is maximum & $P(0)$ is minimum

85. The shortest distance between the line $y - x = 1$ and the curve $x = y^2$ is :

- 1) $\frac{3\sqrt{2}}{8}$ 2) $\frac{2\sqrt{3}}{8}$ 3) $\frac{3\sqrt{2}}{5}$ 4) $\frac{\sqrt{3}}{4}$

Ans : 1

$$2y \frac{dy}{dx} = 1 \Rightarrow \frac{dy}{dx} = \frac{1}{2y} = \frac{1}{2\alpha}$$

Slope of normal = -2α

$$1 \times -2\alpha = -1 \Rightarrow \alpha = 1/2$$

$$\left(\frac{1}{4}, \frac{1}{2}\right) \left| \frac{\frac{1}{2} - \frac{1}{4} - 1}{\sqrt{2}} \right| = \left| \frac{2 - 1 - 4}{4\sqrt{2}} \right| = \frac{3}{4\sqrt{2}} = \frac{3\sqrt{2}}{8}$$

Directions : Questions number **86 to 90** are Assertion - Reason type questions. Each of these questions contains two statements :

Statement-1 (Assertion) and Statement-2 (Reason)

Each of these questions also has four alternative choices, only one of which is the correct answer. You have to select the correct choice.

- 1) Statement-1 is true, Statement-2, is true ; Statement-2 is correct explanation for Statement-1
- 2) Statement-1 is true, Statement-2 is true ; Statement-2 is not a correct explanation for Statement-1 .
- 3) Statement-1 is true, Statement-2 is false
- 4) Statement-1 is false, Statement-2 is true.

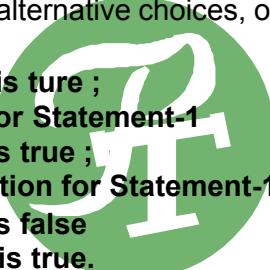

86. Let $f(x) = (x+1)^2 - 1, x \geq -1$ **PADIHEE'S TU TUTORIAL PVT. LTD.**

Statement-1: The set $\{x: f(x) = f^{-1}(x)\} = \{0, -1\}$

Statement-2 : f is a bijection.

Ans : 3

$$f(x) = (x+1)^2 - 1 \quad f^{-1}(x) = -1 + \sqrt{x+1}$$

$$f(x) = f^{-1}(x) \text{ then solution lies on } y = x. \quad (x+1)^2 - 1 = x$$

$$x^2 + x = 0 \quad x = -1, 0$$

Function is one-one but not onto for given domain

87. Let $f(x) = x|x|$ and $g(x) = \sin x$

Statement-1 : gof is differentiable at $x = 0$ and its derivative is continuous at that point.

Statement-2 : gof is twice differentiable at $x = 0$.

Ans : 3

$$g(f(x)) = \begin{cases} \sin(x^2) & x \geq 0 \\ \sin(-x^2) & x < 0 \end{cases}, \text{ g(f(x)) is continuous}$$

$$g'(f(x)) = \begin{cases} 2x \cos(x^2) & x \geq 0 \\ -2x \cos(-x^2) & x < 0 \end{cases}, \quad g''(f(x))^2 = \begin{cases} 2 \cos(x^2) - 4x^2 \sin(x^2) & x \geq 0 \\ -2 \cos(-x^2) - 4x^2 \sin(-x^2) & x < 0 \end{cases}$$

$$g''(f(0+h)) \neq g''(f(0-h))$$

88. **Statement-1 :** The variance of first n even natural numbers is $\frac{n^2 - 1}{4}$.

Statement-2 : The sum of first n natural numbers is $\frac{n(n+1)}{2}$ and the sum of squares of first n natural

numbers is $\frac{n(n+1)(2n+1)}{6}$.

Ans : 4

$$\begin{aligned}
 \text{Variance} &= \frac{\sum x_i^2}{x} - \left(\frac{\sum x_i}{x} \right)^2 \\
 &= 4 \left[\frac{1^2 + 2^2 + 3^2 + \dots + n^2}{n} \right] - 4 \left(\frac{1 + 2 + 3 + \dots + n}{n} \right)^2 \\
 &= \frac{2}{3} (n+1)(2n+1) - (n+1)^2 \\
 &= \frac{(n+1)}{3} [4n+2 - 3n-3] = \frac{n^2-1}{3} \\
 &= \frac{n(n+1)(2n+1)}{6}
 \end{aligned}$$



89. **Statement-1:** $\sim(p \leftrightarrow \sim q)$ is equivalent to $p \leftrightarrow q$

Statement-2: $\sim(p \leftrightarrow \sim q)$ is a tautology.

Ans: 3

90. Let A be a 2×2 matrix

Statement-1: $\text{adj}(\text{adj}A) = A$

Statement-2: $|\text{adj}A| = |A|$.

Ans: 1

We know $\text{adj}(\text{adj}A) = |A|^{n-2} \cdot A$

$A(\text{adj}A) = |A| I_n$ and $|\text{adj}A| = |A|^{n-1}$

Put $n = 2$